

CONTROL PANEL FOR
PASSENGER ELEVATOR MODERNIZATION

Modernization by Multi-Brand Integration



World-Class Control



Flexibility for Your Markets

Our Multi-Brand Modernization ensures safety and comfortable ride of your elevator by using a Mitsubishi control panel. Our control panel is designed to be highly compatible with advanced equipment available in your markets, providing flexibility to meet requirements such as, spatial design, budgets, and delivery schedules.

By positioning the control panel as the cornerstone of our partial replacement solution, we deliver Mitsubishi Quality that ensures reliability, safety, and operational efficiency.



> Quality

Mitsubishi control panel

Our intelligence × Reliability × Stable performance

Our highly-reliable control panel ensures safety and comfortable ride. Incorporating our overall quality enhances your asset value.

Mitsubishi car/hall indicators

Upgrading to the Mitsubishi's latest indicators enhances the overall appearance.



PIH-D427B
OPTIONAL



HLP3-A16 Projection lantern without screen
OPTIONAL

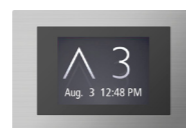

PIH-C117
OPTIONAL



PIV-C766N
OPTIONAL



HBV-A1410N
OPTIONAL



CBV-C730E
OPTIONAL

To select other designs, please consult our local agents.

> Flexibility

Utilizing other vendor's traction machines

Simply connecting our control panel to an other vendor's traction machine, and the auto-tuning function will optimize performance for maximum ride comfort. We provide solutions customized to fit the limitations of your existing machine room.

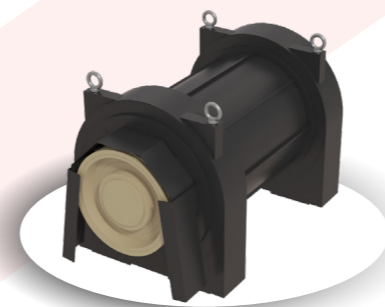

Flexible local component arrangement

Our control panel is compatible with local components available in various markets. Our Multi-Brand Modernization adapts flexibly to your needs. For example, by selecting suppliers based on budgets, delivery schedules, and specifications.

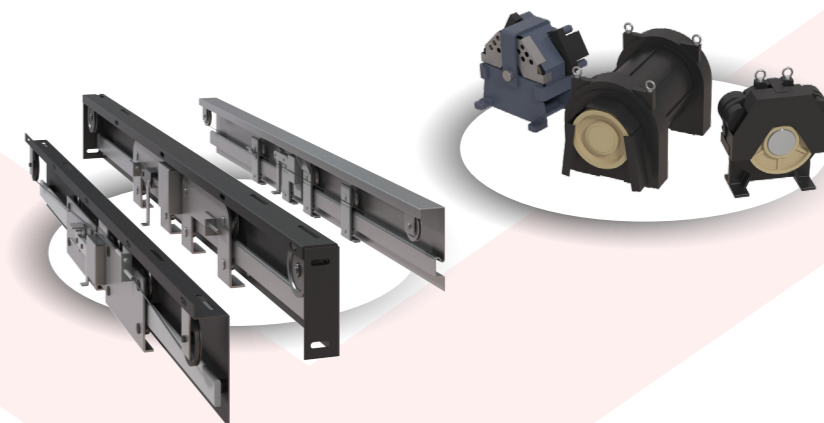

> Friendliness

Friendly to everyone

By positioning the control panel as the cornerstone of our partial replacement, we can deliver a smarter experience through seamless building integration, sustainable operations through optimal use of existing assets, and serviceability with local components—all backed by long-lasting reliable Mitsubishi Quality.

User-Friendly

- **Premium comfort**
A smoother and more comfortable ride for all passengers
- **Seamless integration**
High compatibility with building systems (DOAS, robot operation, etc.)



Please consult our local agents for applicability.

Eco-Friendly

- **Sustainable modernization**
Strategic partial replacement that maximizes the value of existing assets
- **High efficiency**
Energy-saving operation driven by Mitsubishi's advanced control technology

Maintenance-Friendly

- **Reliable serviceability**
Designed for ease of maintenance with readily available local components
- **Proven support**
Superior maintenance competence through our Mitsubishi control systems and service network

Mitsubishi-Friendly

- **Long-term assurance**
Ensure confidence by establishing long-lasting relationships with Mitsubishi

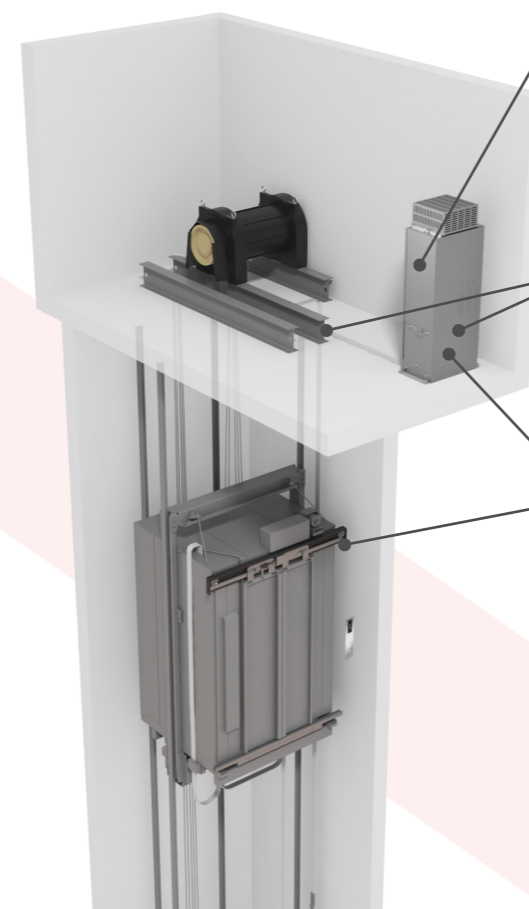

Specifications

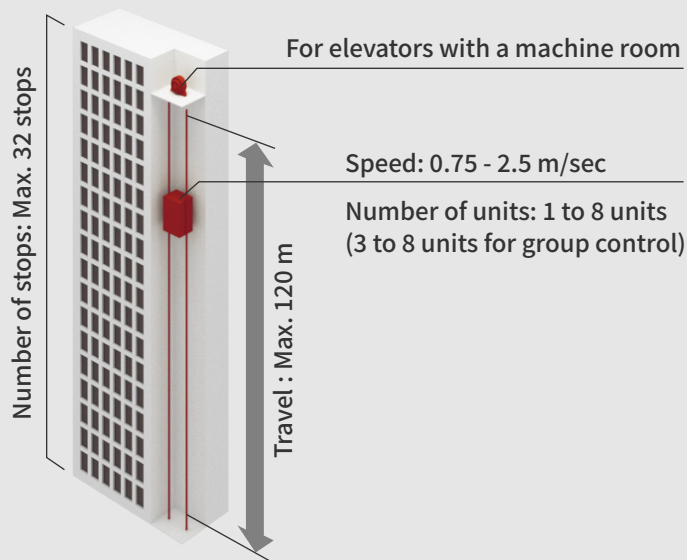

We offer solutions tailored to your needs and market demands to ensure your elevators meet the local codes and regulations.

For further information about our Multi-Brand Modernization, including a comparison of available options, please consult our local agents.



Website

MITSUBISHI ELECTRIC BUILDING SOLUTIONS CORPORATION

HEAD OFFICE : TOKYO BLDG., 2-7-3, MARUNOUCHI, CHIYODA-KU, TOKYO 100-8310, JAPAN
<https://www.MEBS.com>

⚠ Safety Tips: Be sure to read the instruction manual fully before using this product.